

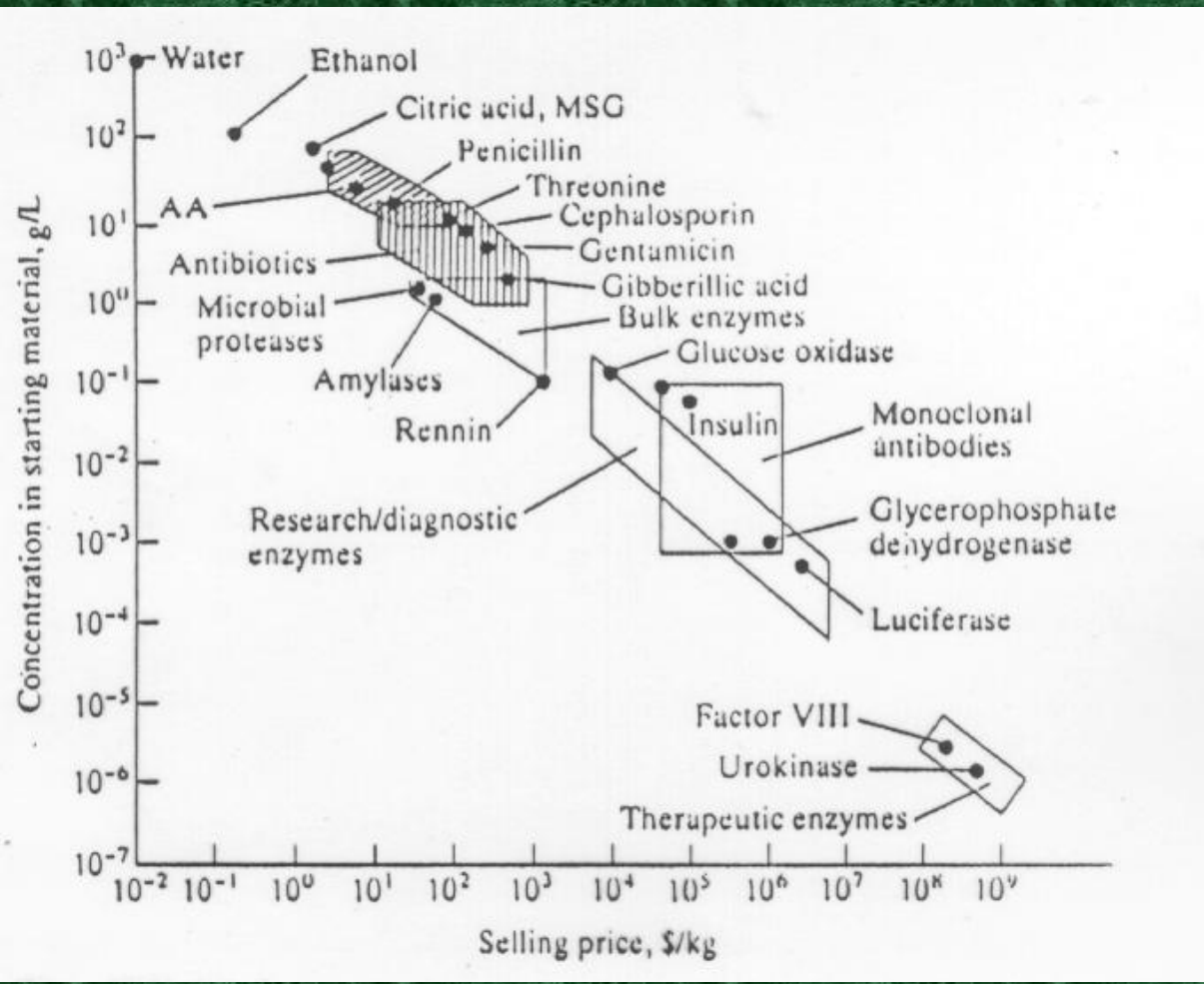
**INFLUENCE OF BIOREACTOR  
ENGINEERING PARAMETERS ON  
PRODUCT FORMATION IN GAS  
MIXED REACTORS**

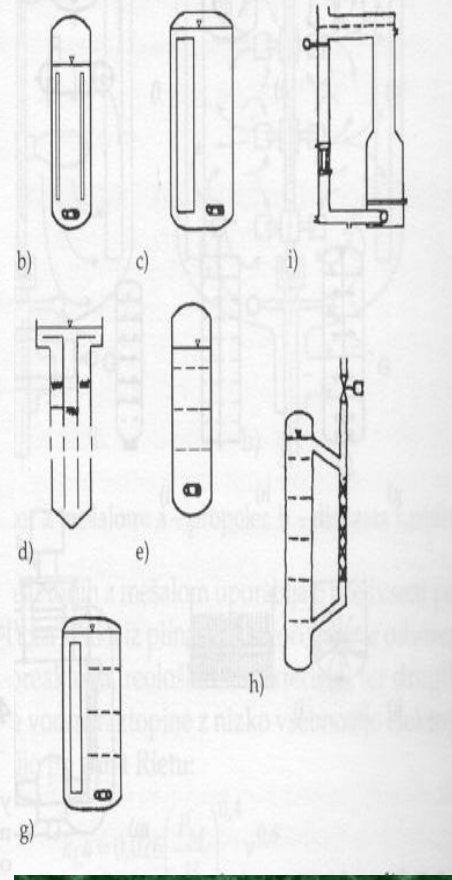
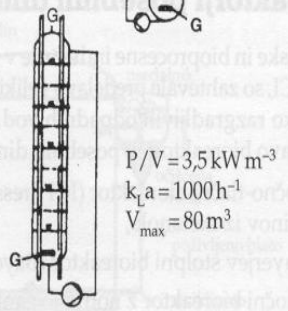
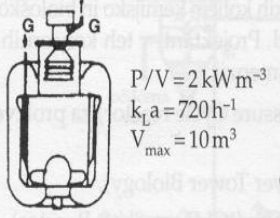
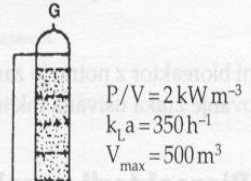
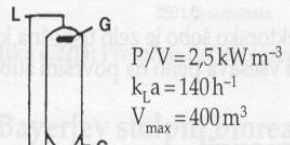
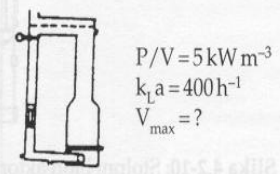
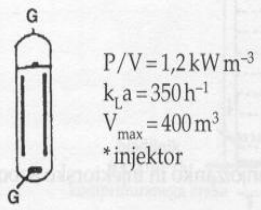
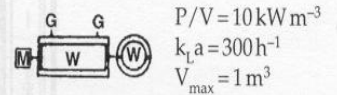
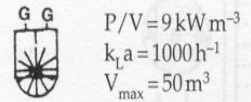
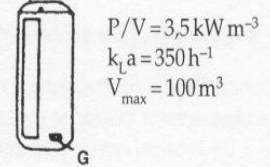
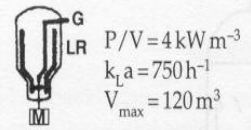
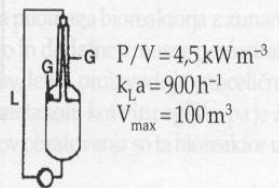
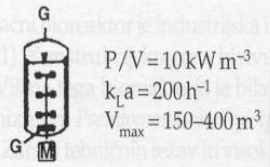
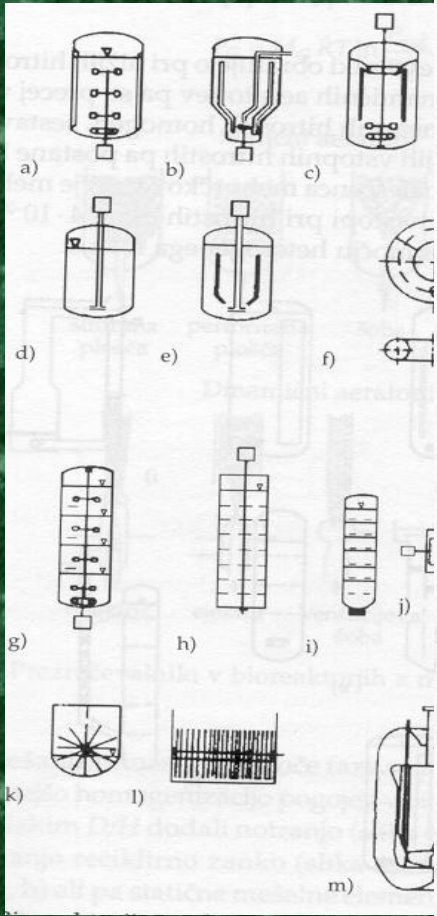
**Marin Berovič**

**Department of Chemical and Biochemical Engineering**

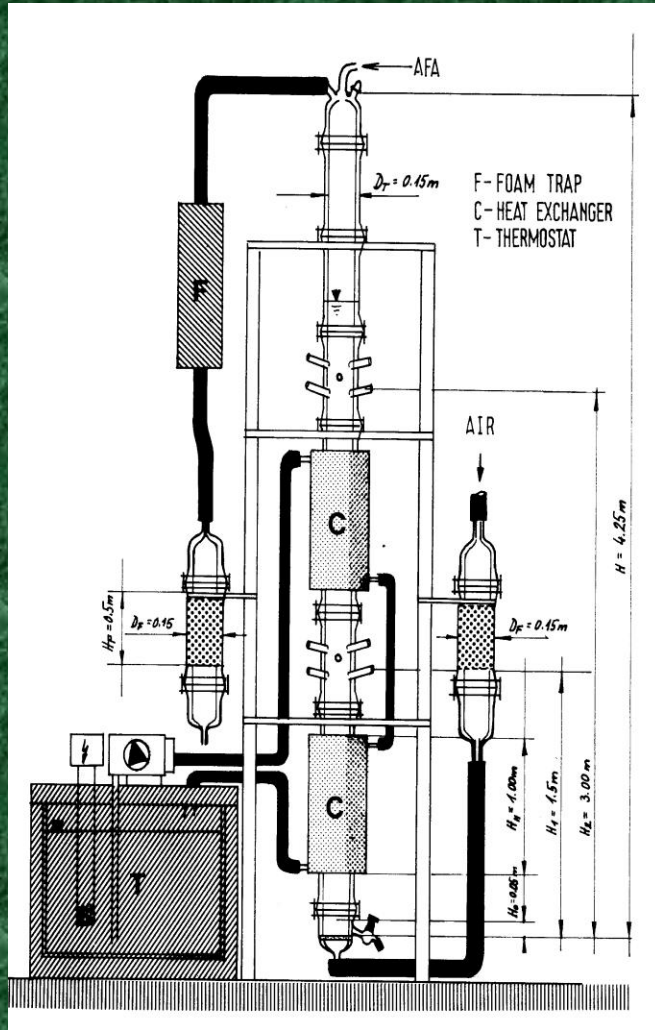
**University of Ljubljana**

**Slovenia**

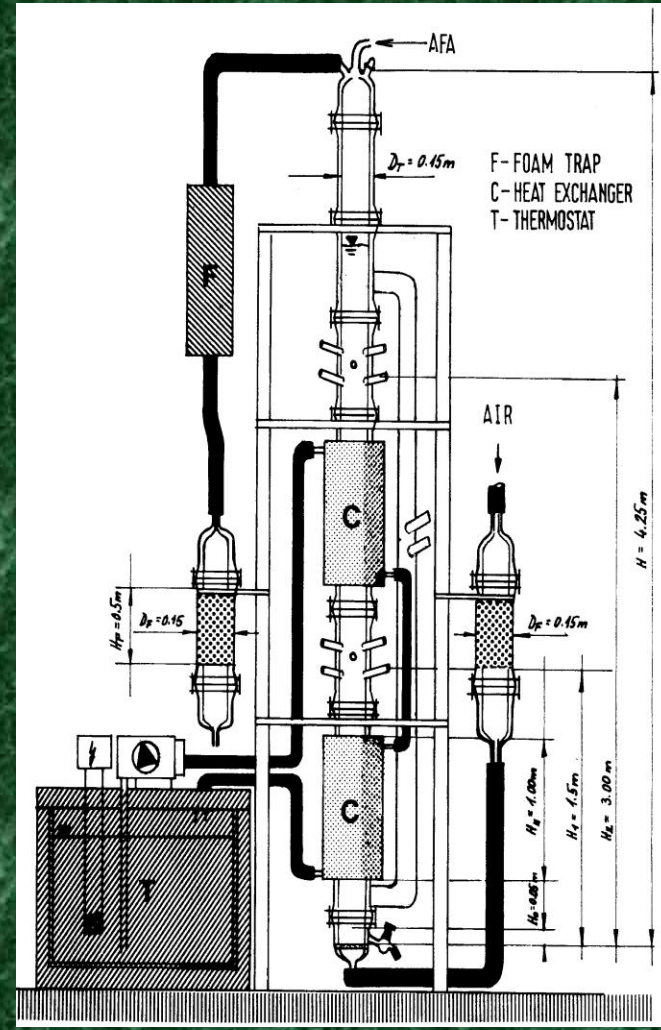




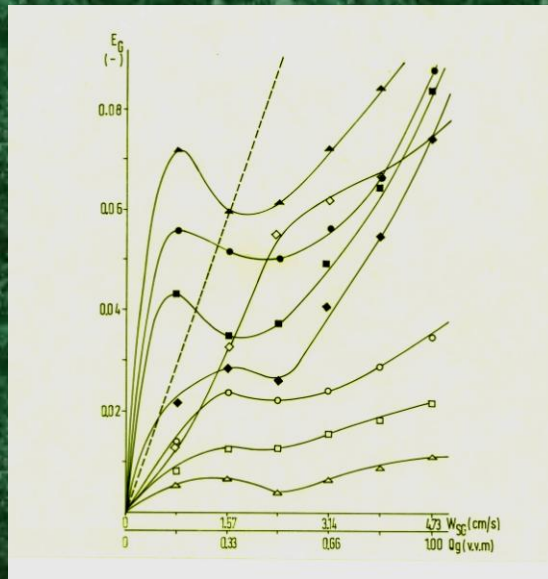




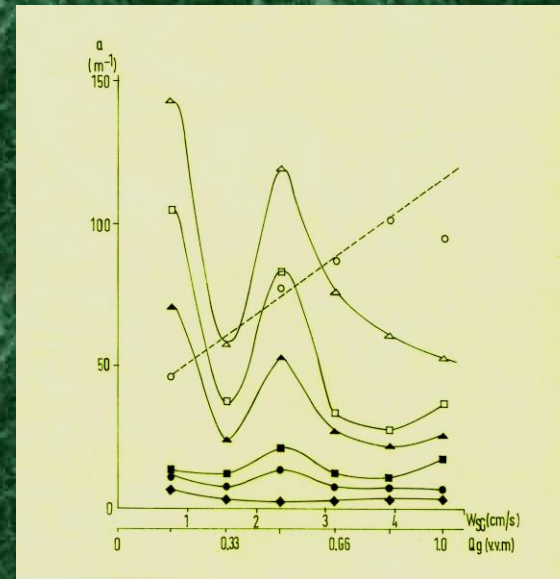
Buble Column Reactor



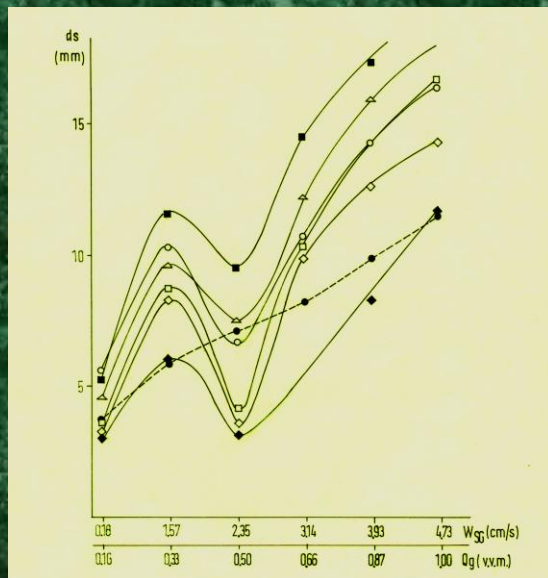
External Loop Reactor



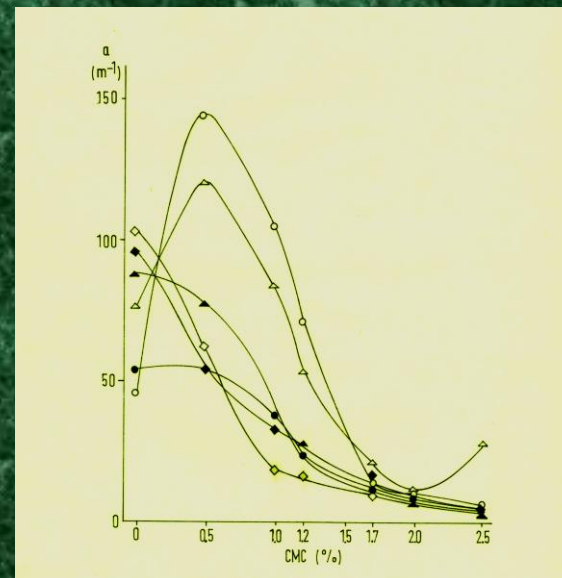
**Gas Hold Up**



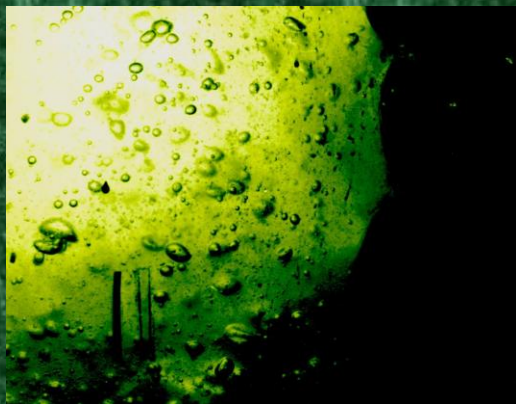
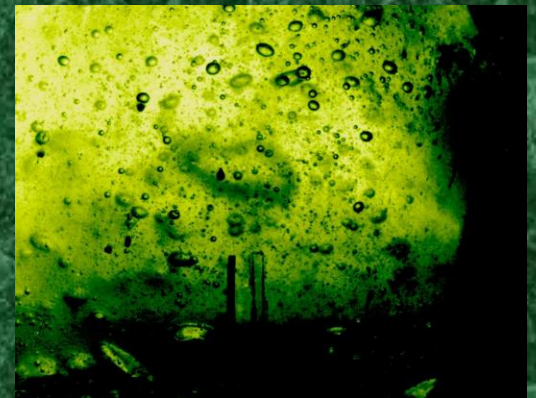
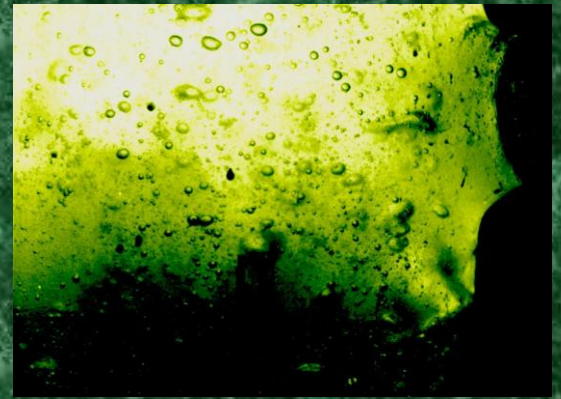
**Specific interfacial area**

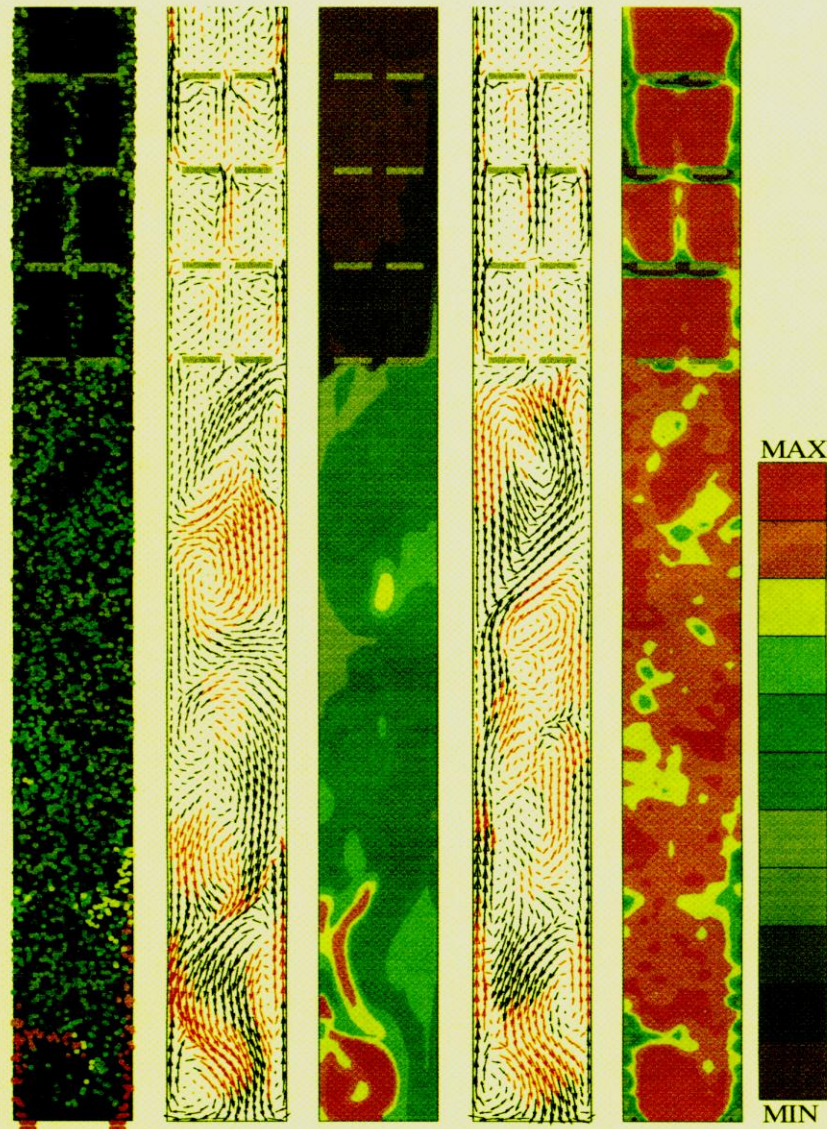


**Sauter mean diameter**

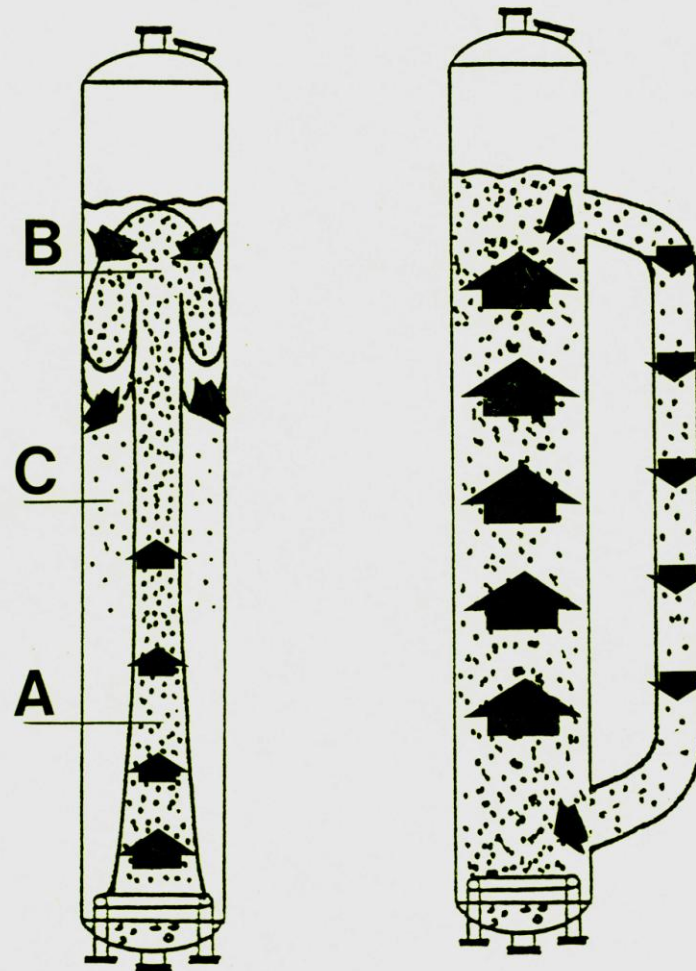


**Specific interfacial area**

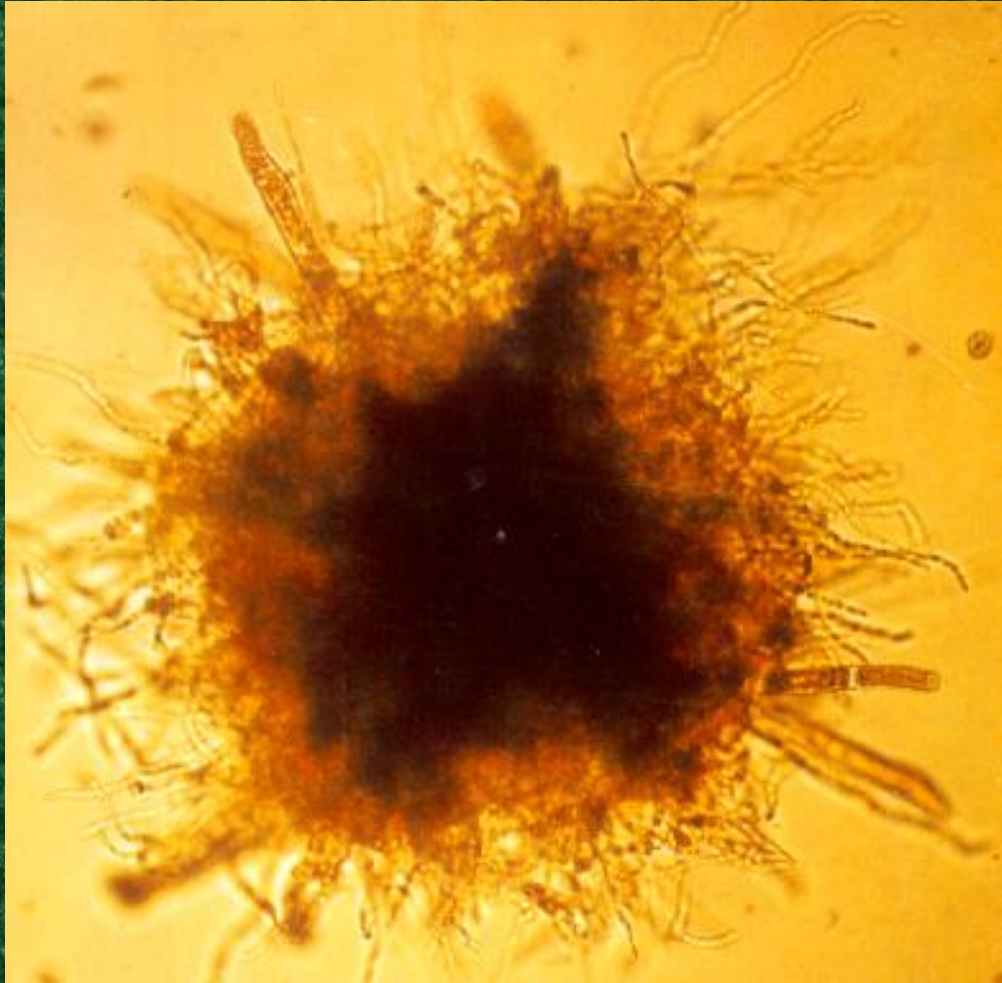


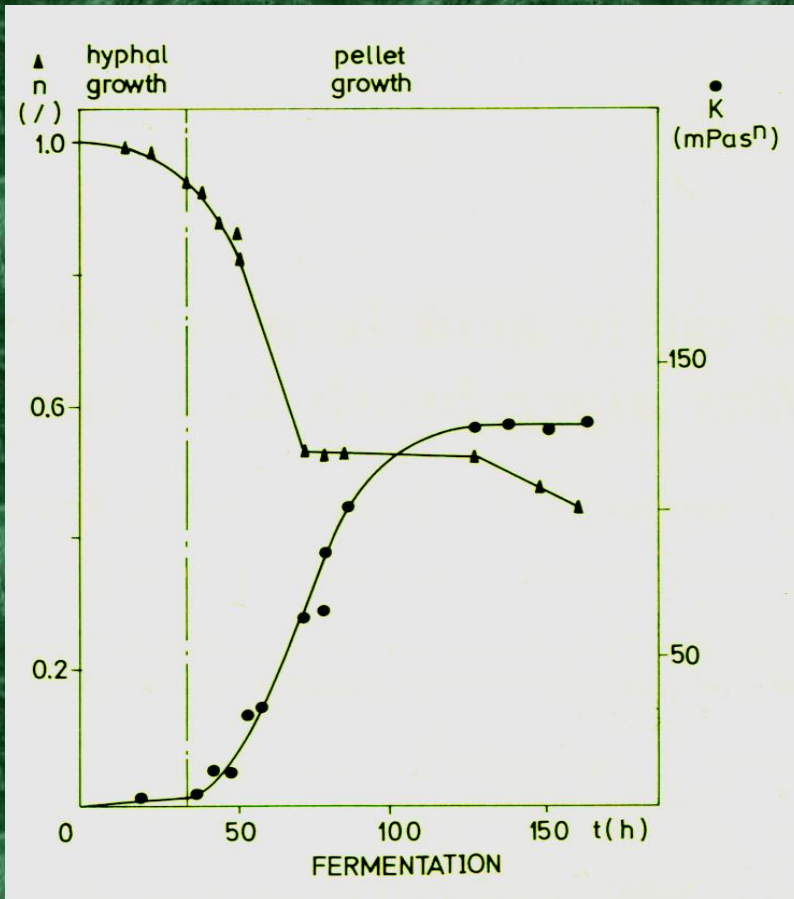


**Heat and Mass Transfer in Bubble Column Reactors**

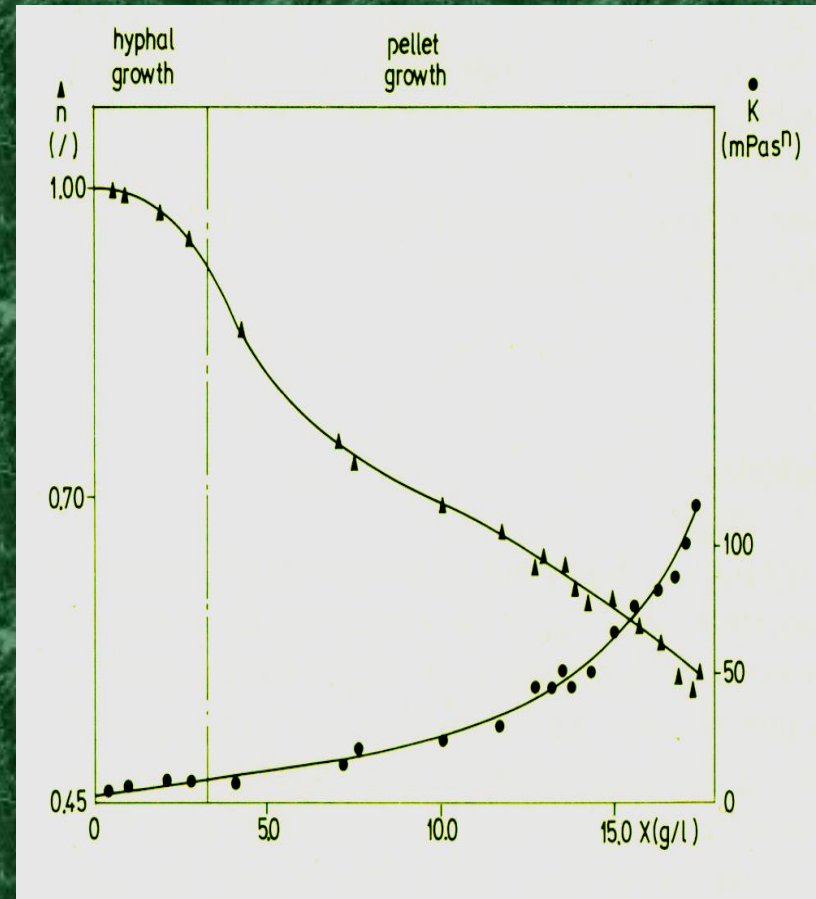


**Mixing in Bubble Column and  
External Loop Reactors**

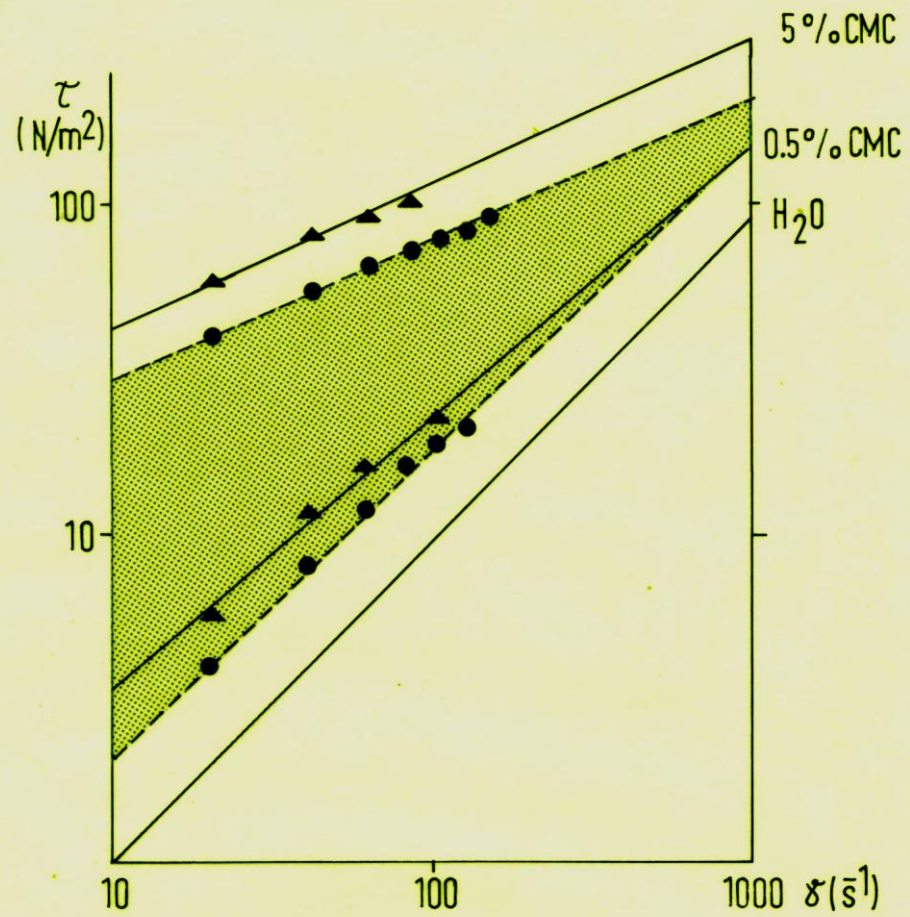


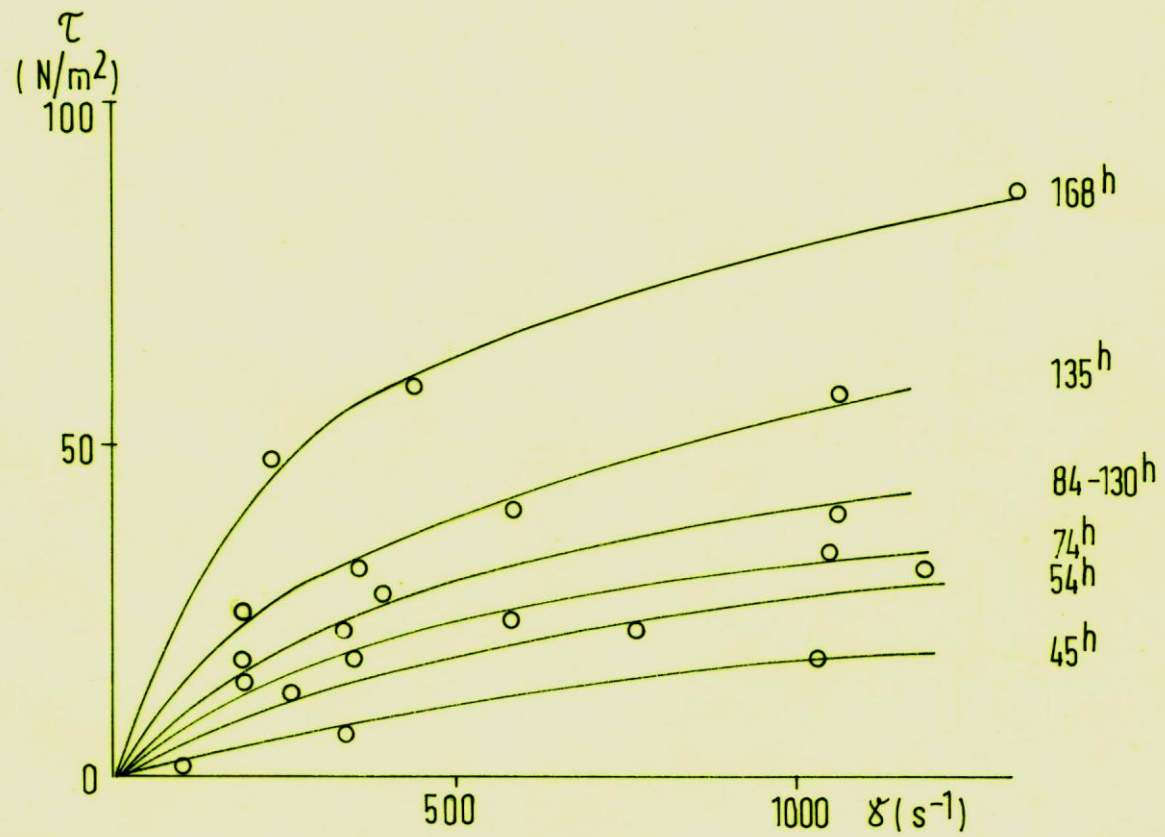


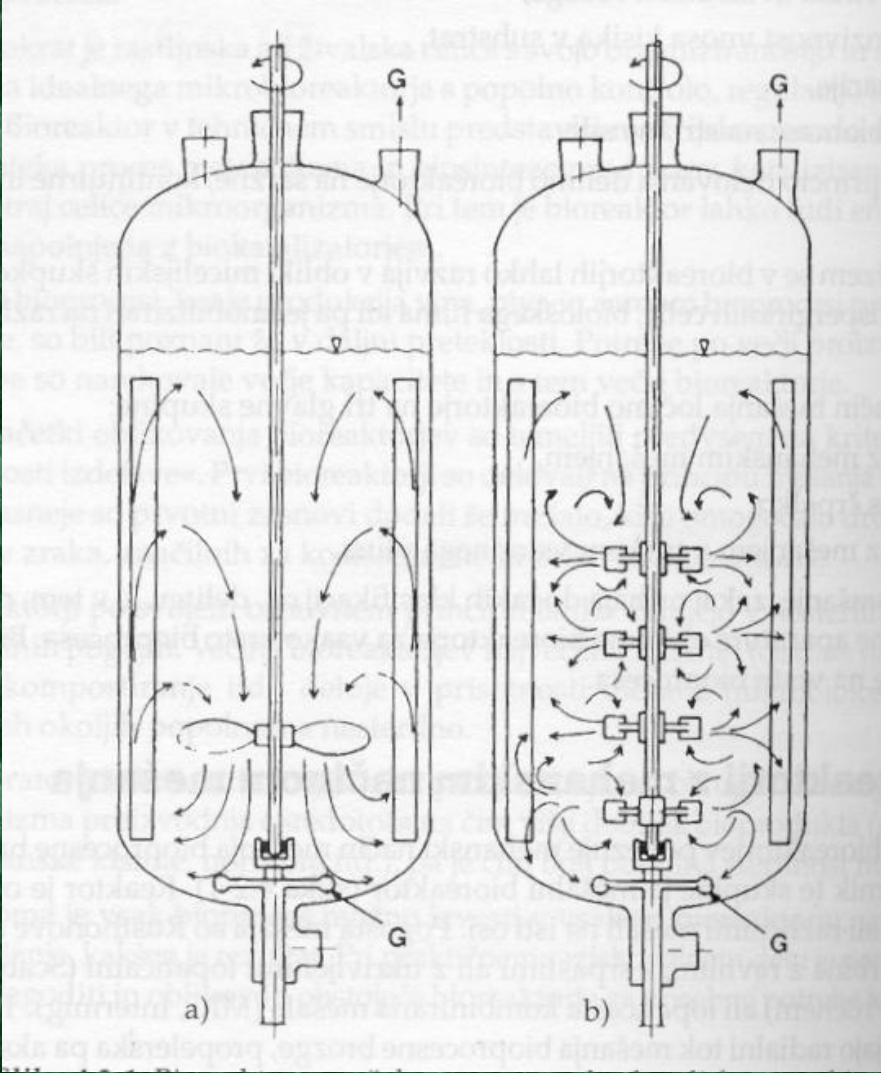
**Fig. 2.** The courses of the flow behaviour index ( $n$ ) and fluid consistency index ( $K$ ) of the fermentation broth during the whole fermentation period (shear rate,  $\dot{\gamma} = 100\text{--}1000 \text{ s}^{-1}$ )

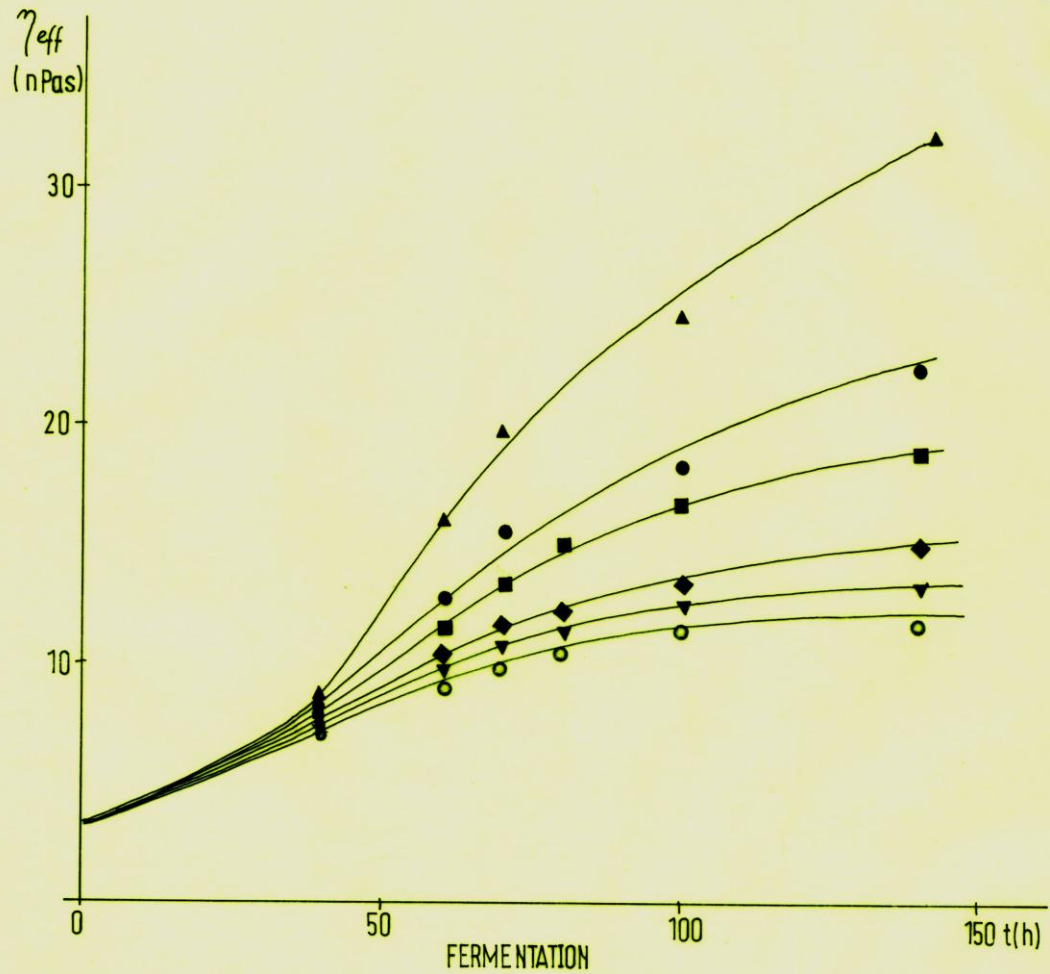


**Fig. 3.** Relationship between the flow behaviour index ( $n$ ) and biomass concentration ( $X$ )







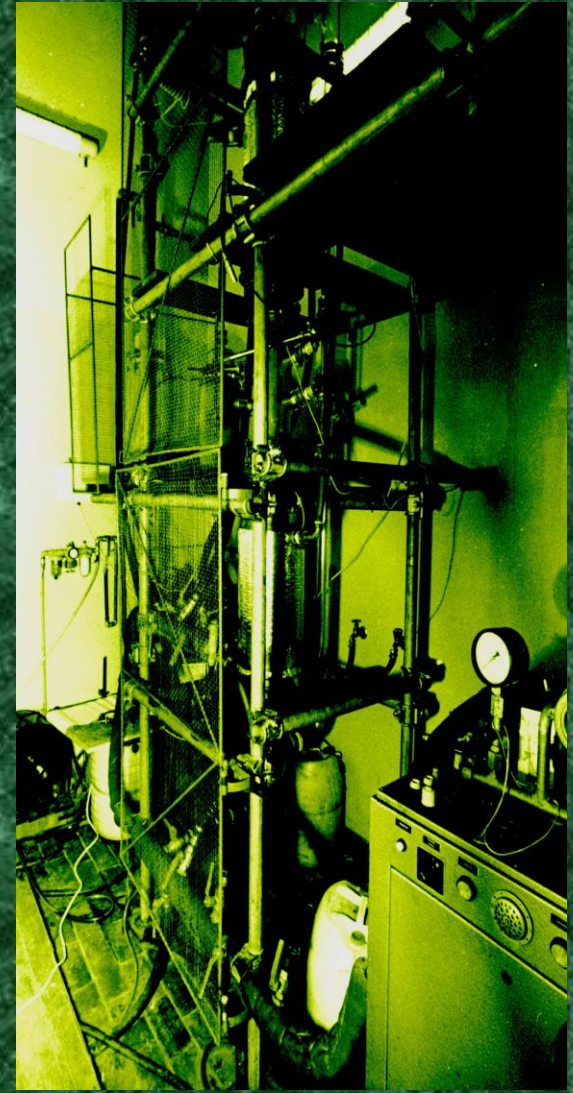




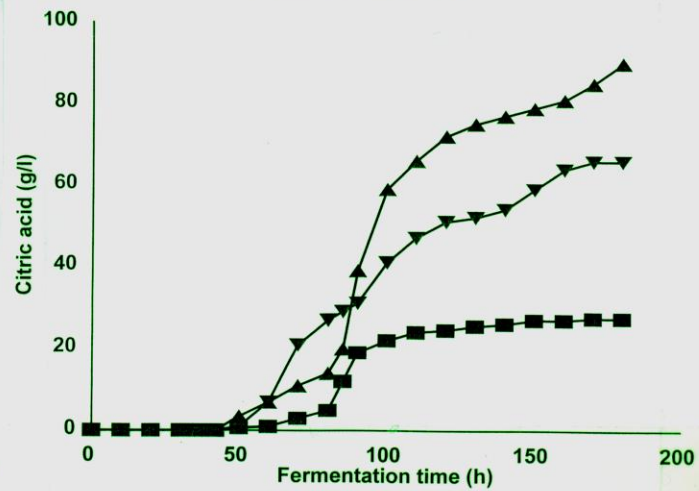
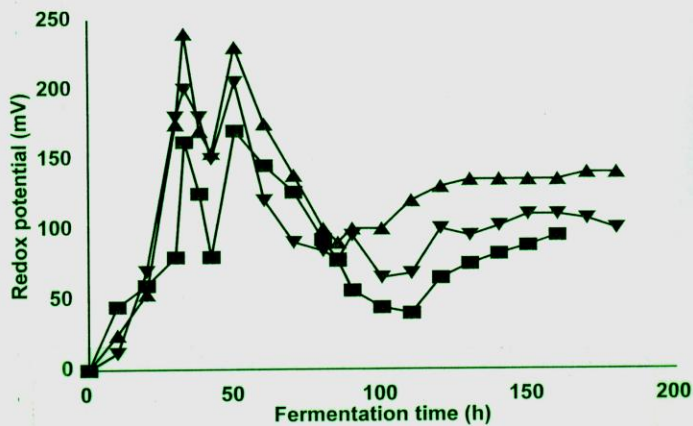
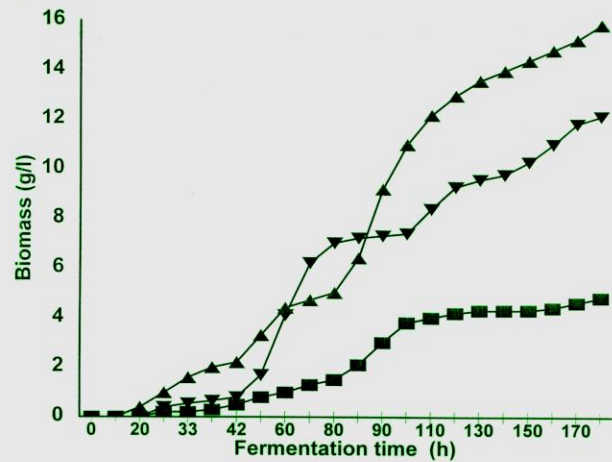
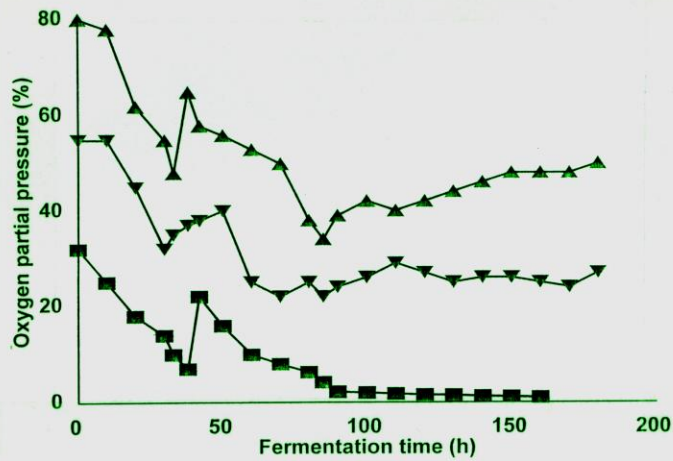
**50 L Bubble Column  
Reactor**

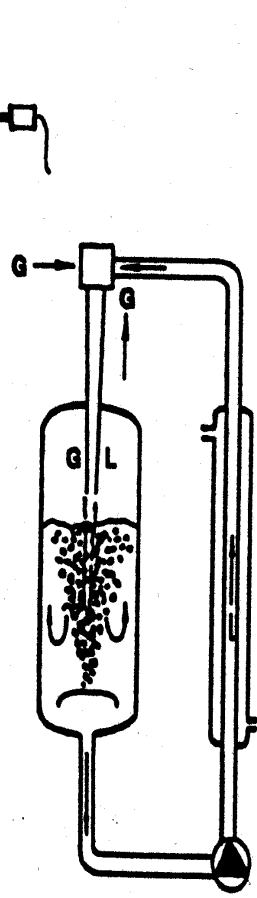
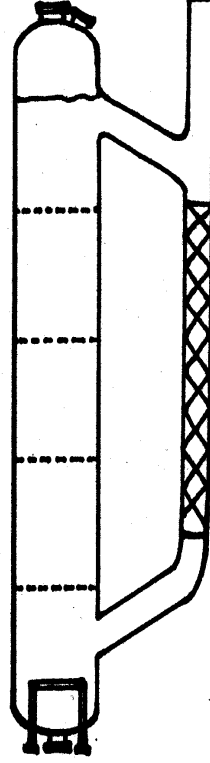
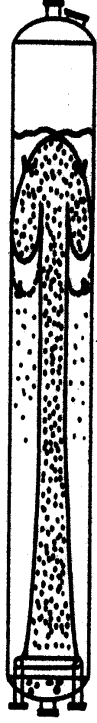
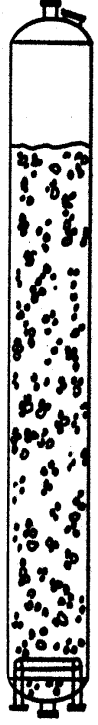


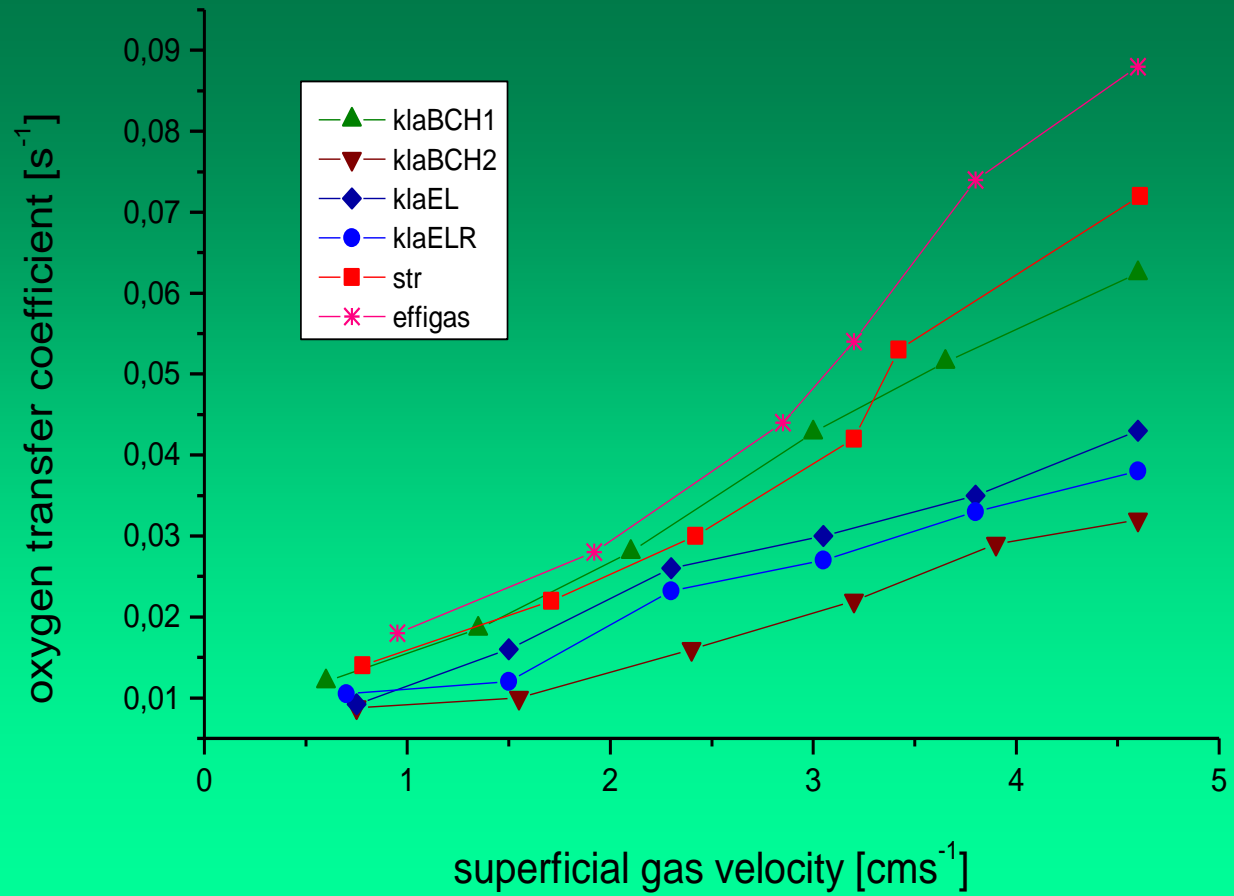
**5 L Model Bubble  
Column Reactor**

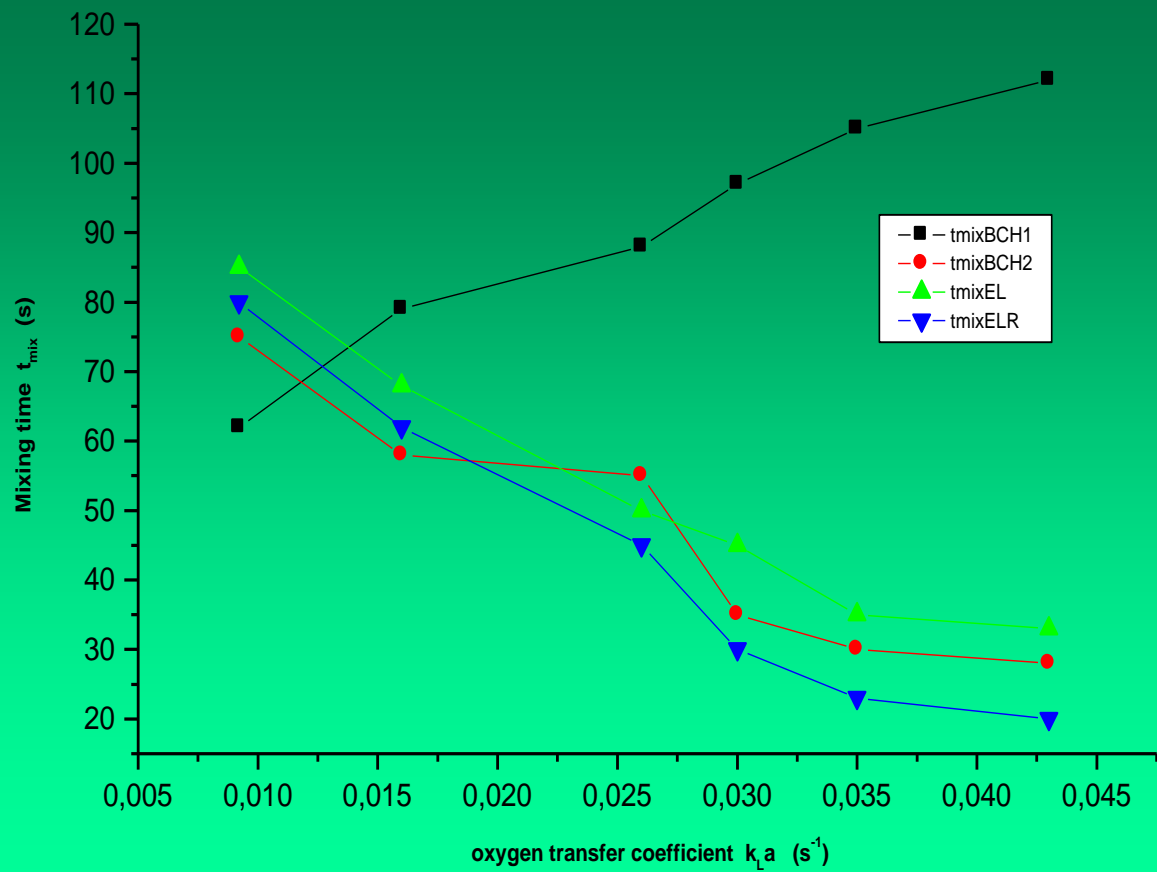


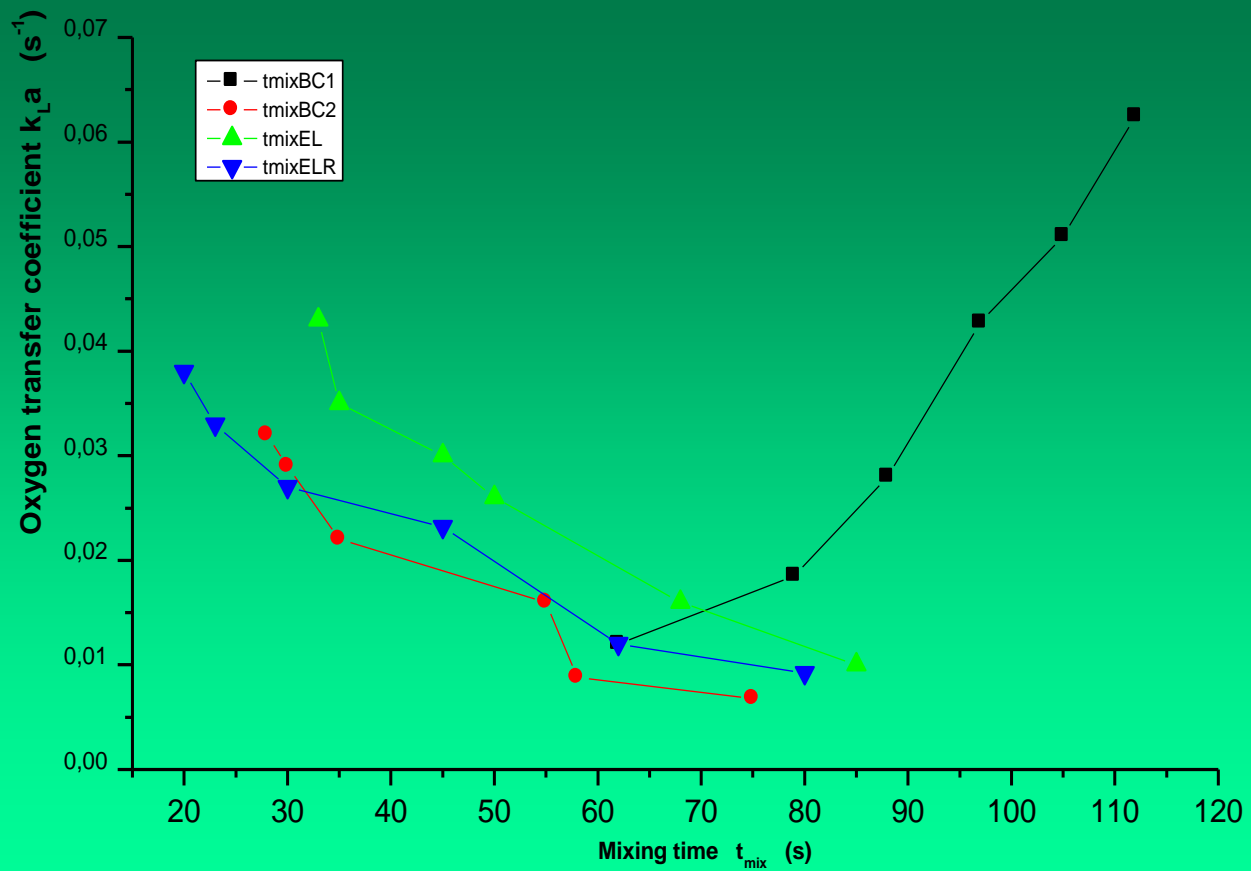
**50 L External Loop  
Reactor**

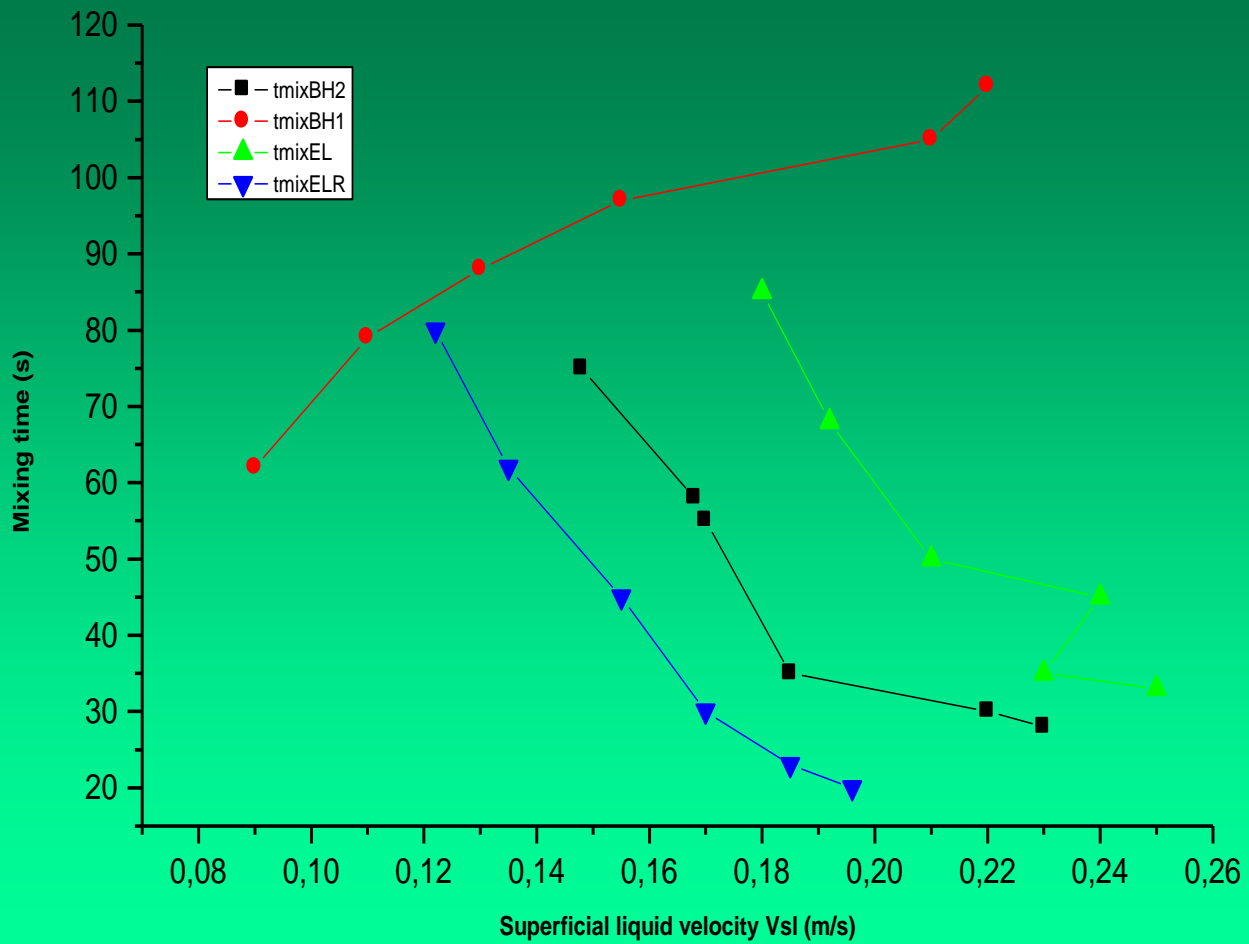


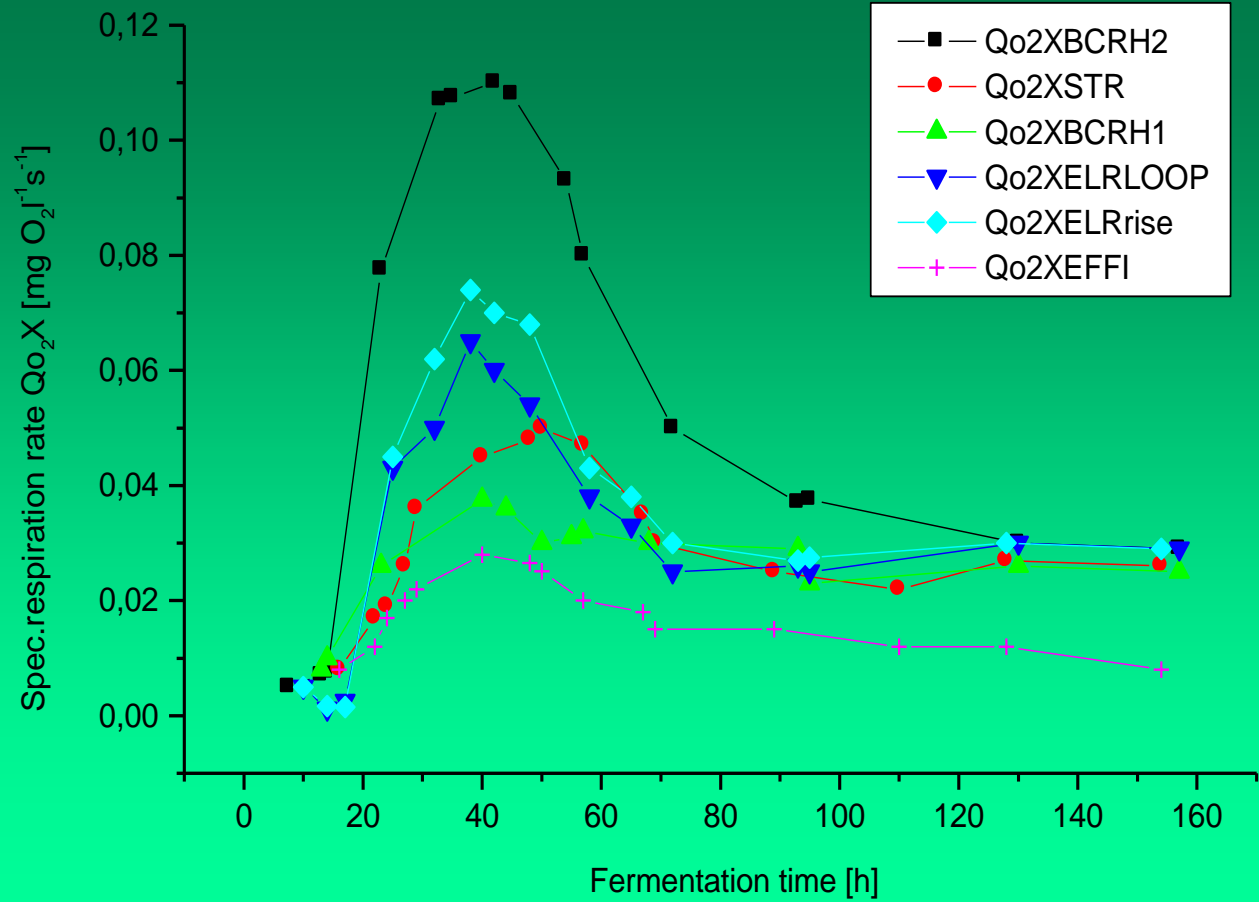


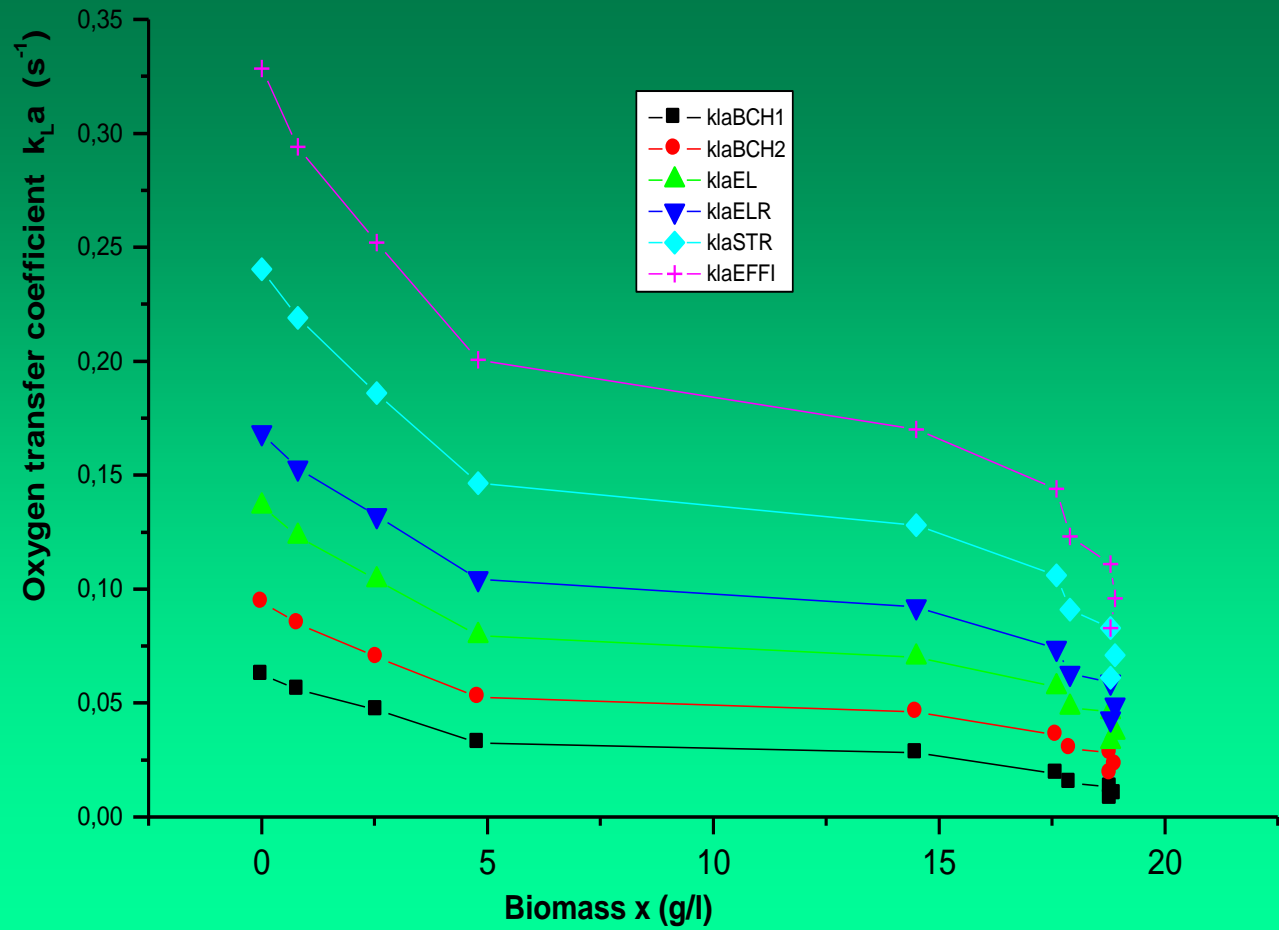


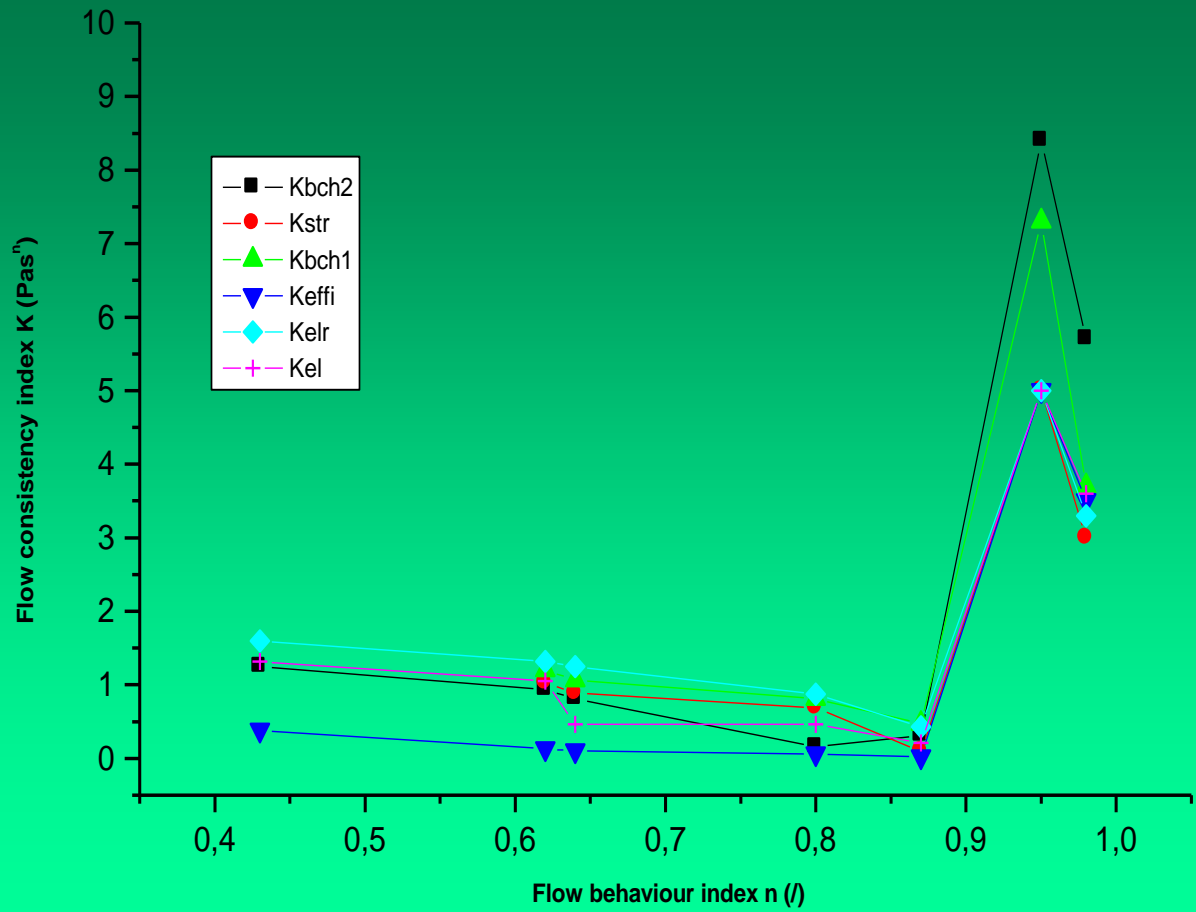


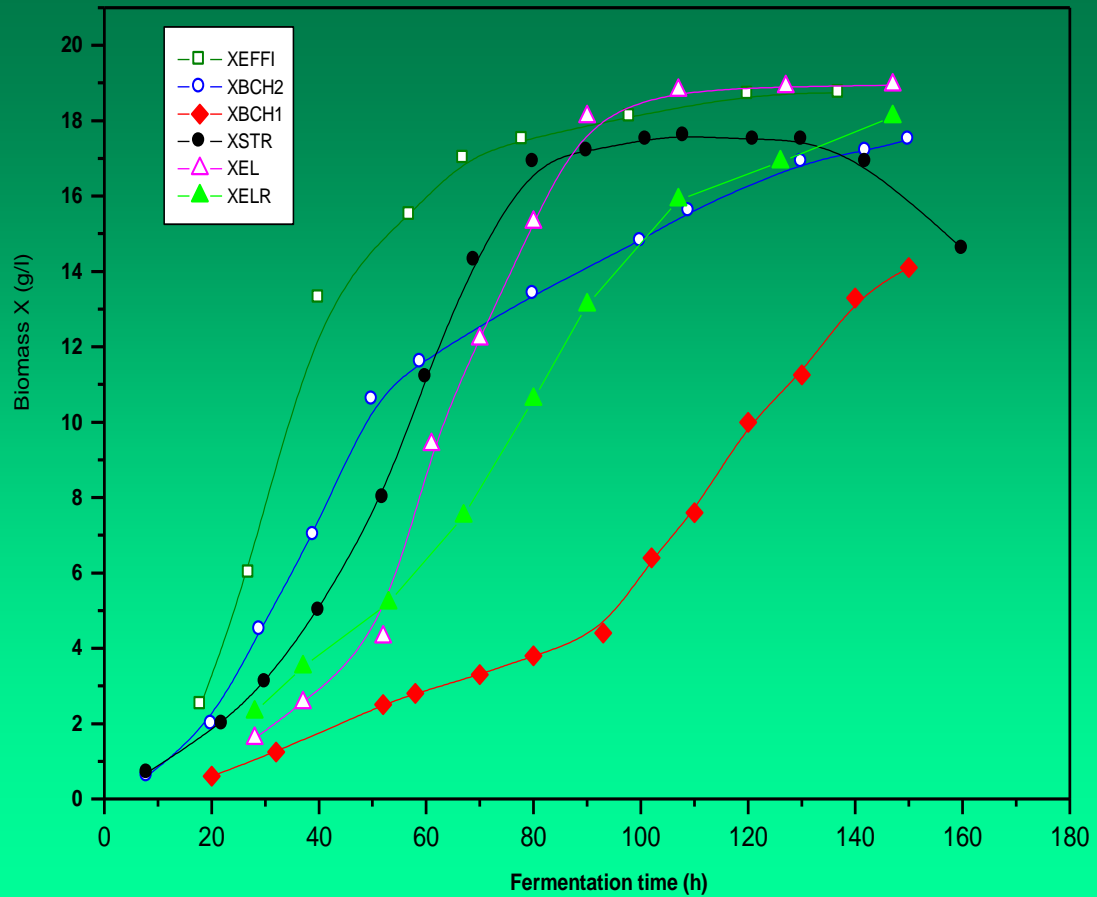


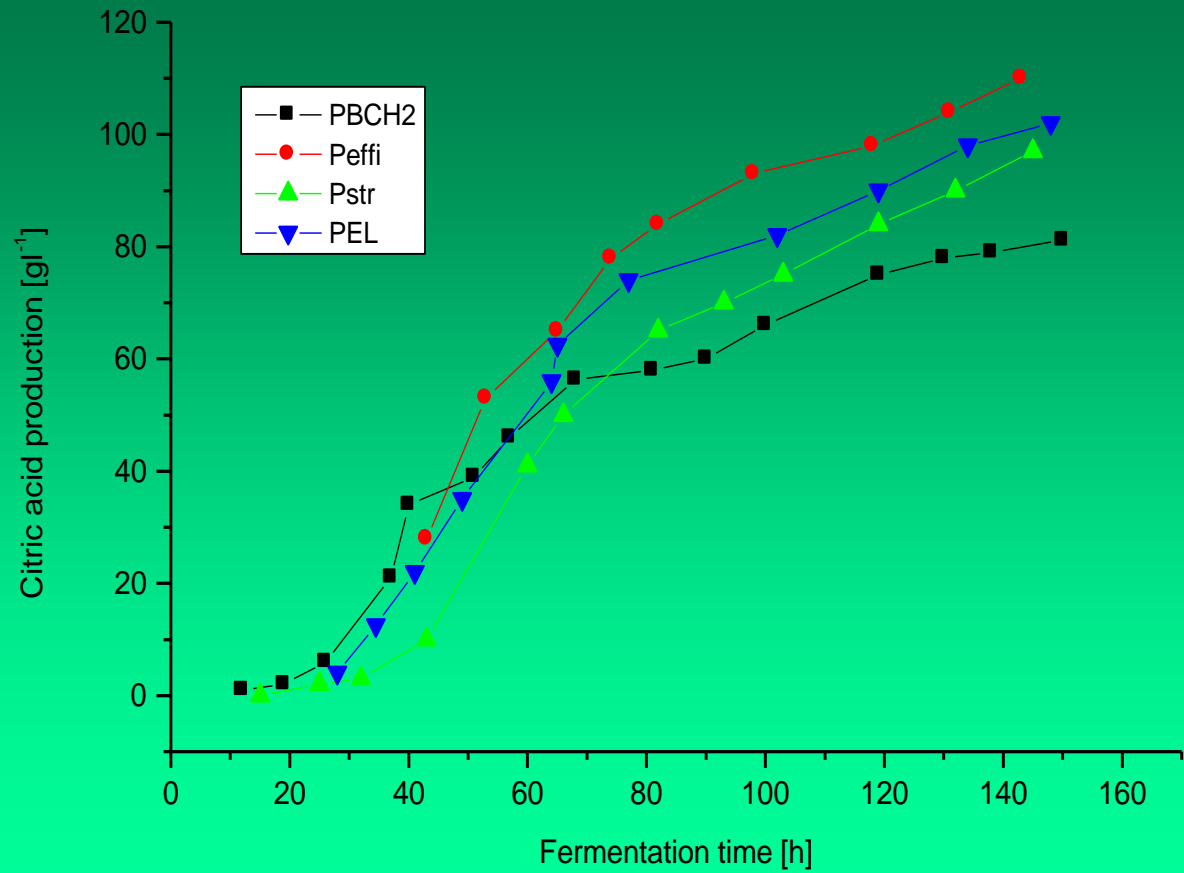


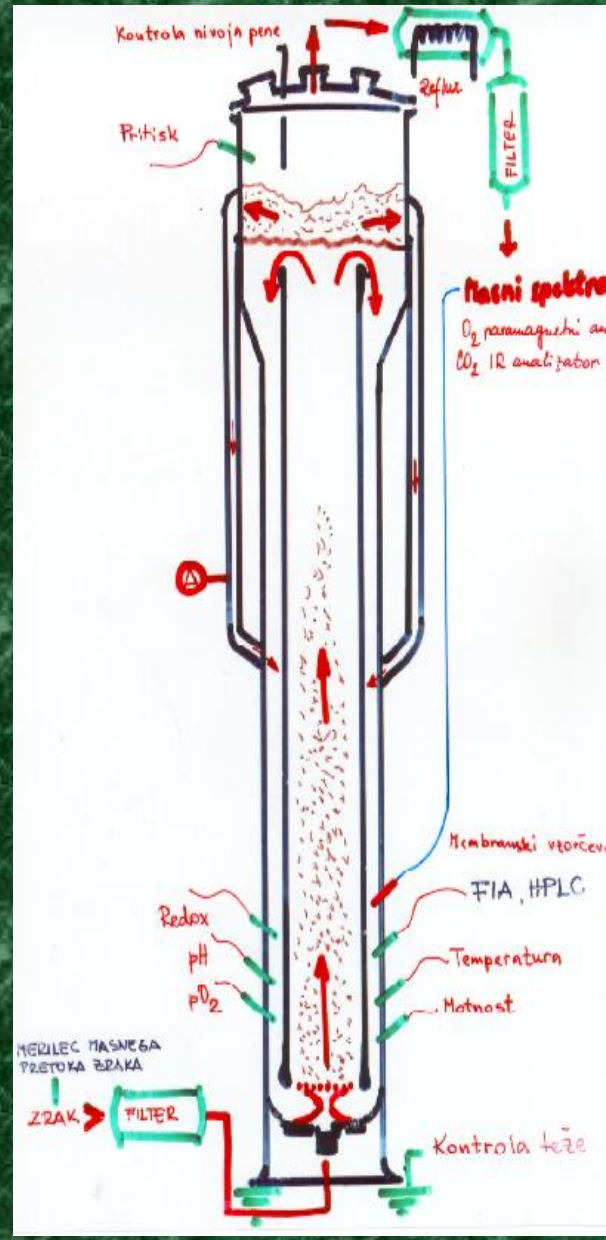
















[digitalblasphemy.com](http://digitalblasphemy.com)